

TRAIL-SLING ULTRALIGHT - - ASSEMBLY INSTRUCTIONS

STEP 1

BEFORE BEGINNING YOU MUST ORIENT FRAME AS SHOWN!

INSTRUCTIONS TO "EXTEND FRAME" SHOULD BE FACING YOU.

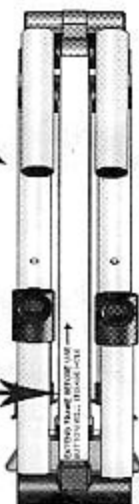

STEP 2

EXTEND THE 4 TEE SUPPORTS AS SHOWN. SHOCK-CORDS WILL HOLD THEM IN PLACE

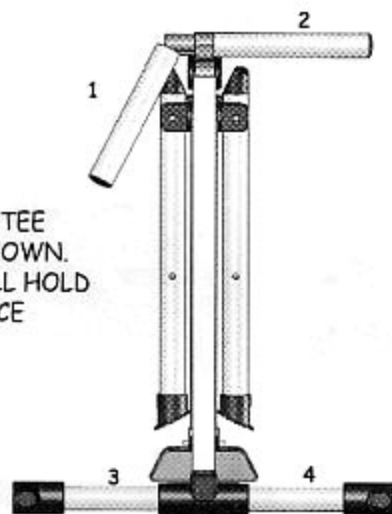

STEP 3

EXTEND TELESCOPING CENTER SPINE DOWNWARD UNTIL BUTTON ENGAGES

CENTER SPINE

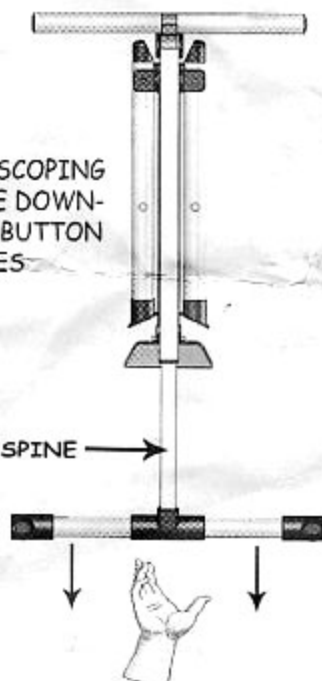

STEP 4

SLIDE COLLAR DOWN REAR SPINE UNTIL BUTTON ENGAGES.

REAR LEG COLLAR WITH BUTTON HOLE

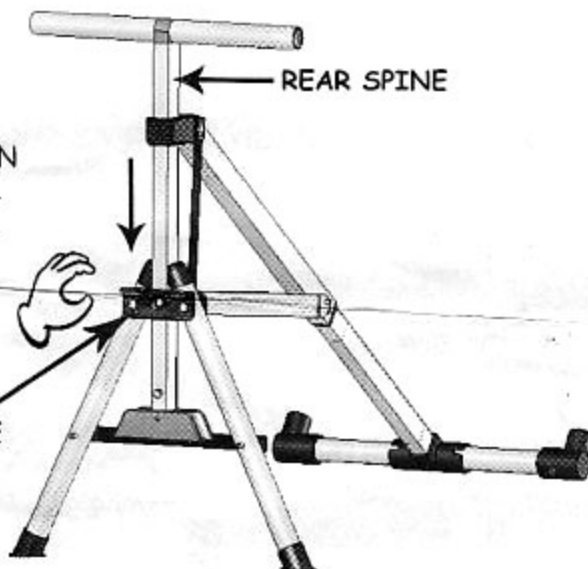

STEP 5

SET FRAME AS SHOWN. REAR SPINE BUTTON SHOULD BE FULLY ENGAGED.

REAR SPINE COLLAR

REAR LEG COLLAR WITH BUTTON FULLY ENGAGED!

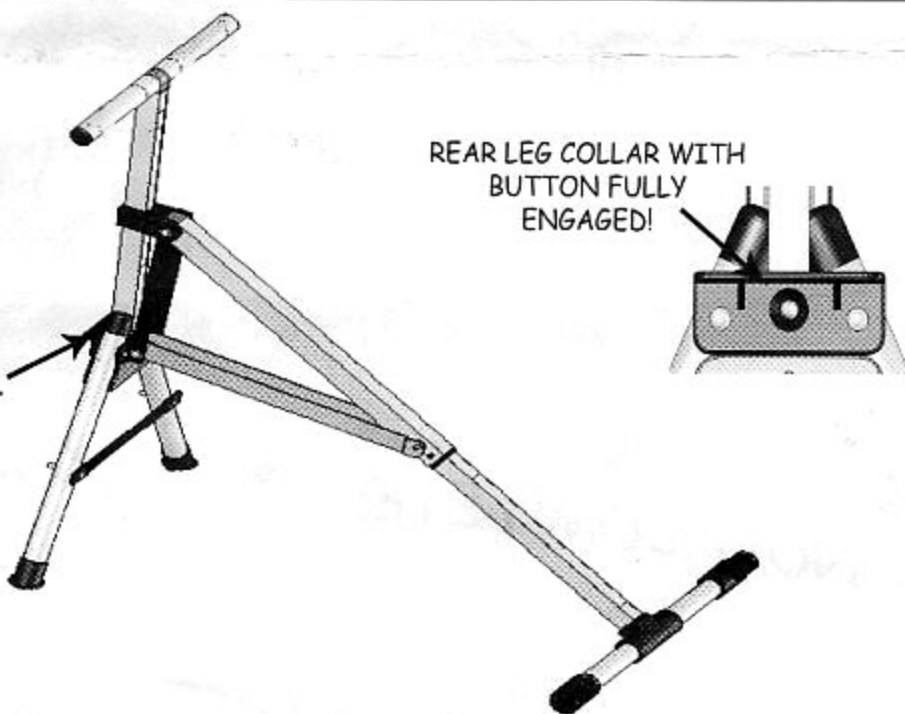

TRAIL-SLING ULTRALIGHT- - ASSEMBLY INSTRUCTIONS

STEP 6

UNROLL SEAT FABRIC AND UNFOLD SEAT SUPPORT FRAME



STEP 7

INSERT LEGS OF SEAT SUPPORT FRAME INTO FRONT FEET OF CHAIR

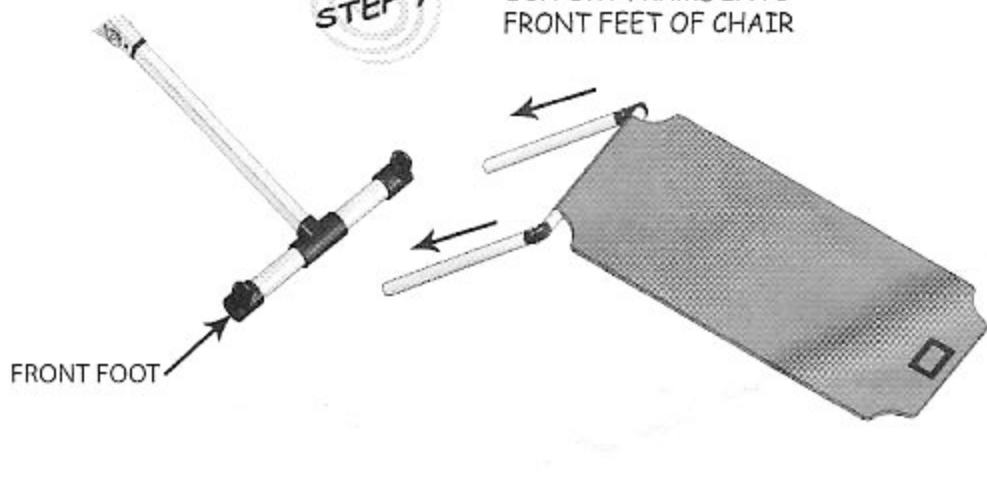

STEP 8

POSITION CHAIR AS SHOWN

ROTATE FABRIC UPWARD TO TOP OF CHAIR FRAME. INSERT ONE TEE SUPPORT INTO FABRIC WINDOW EXACTLY AS SHOWN. TEE SUPPORT SHOULD NOT BE DISENGAGED.



STEP 9

DISENGAGE EXPOSED TEE SUPPORT, AS SHOWN. ROTATE AND INSERT OPEN SIDE OF FABRIC

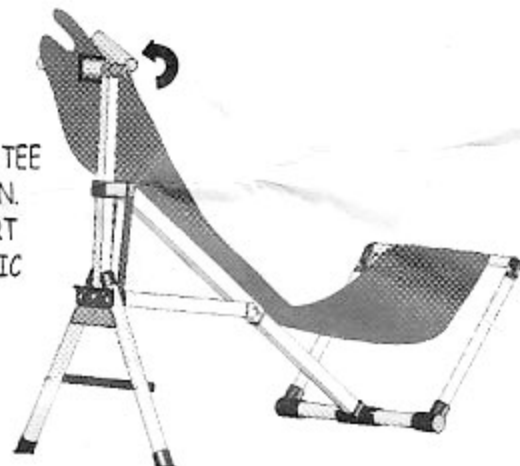

STEP 10

SLIDE SEAT FABRIC OVER TEE SUPPORT AND RE-ENGAGE.



YOUR TRAIL-SLING IS NOW COMPLETE!